

Donaldson®
Torit®

**POWERCORE® SILO
VENTING COLLECTORS**

SVU SERIES



SMALLER. SMARTER SILO VENTING FILTERS

THE COMPACT SVU SERIES BRINGS THE PERFORMANCE AND CONVENIENCE OF THE POWERCORE® TECHNOLOGY TO THE SILO VENTING MARKET.

Built to withstand severe weather conditions, the SVU series is specially designed for use on pneumatically filled storage silos with airflows up to 1175 cfm (2000 m³/hr).

The PowerCore SVU Series will satisfy the need not only for efficiency and reduced maintenance, but also for convenience and workers' safety. You can't always avoid having your maintenance workers climbing and working on high height silos, but you can control how convenient and safe it is. The SVU's compact and low design provides easy and safe access to the filter packs.

With the Silo Venting Unit, you can save space, reduce maintenance requirements and hazards generated by changing long and dirty filter bags or cartridges on a silo top. Thanks to the PowerCore technology, while up to 6 filter bags have to be moved up and down on conventional silo venting solutions, the SVU only needs 2 compact and lightweight filter packs; Changing the PowerCore filter packs can be done easily and safely by just one person with no tools or losable part, in no time.

Time-consuming and often very dirty maintenance processes, frequently under precarious working conditions, are a thing of the past when using the PowerCore SVU Series.

UP TO **54%** SHORTER THAN TRADITIONAL SILO VENTING COLLECTORS

Difference between Donaldson® PowerCore® SVU Series and a traditional silo venting collector using filter bags or cartridges.

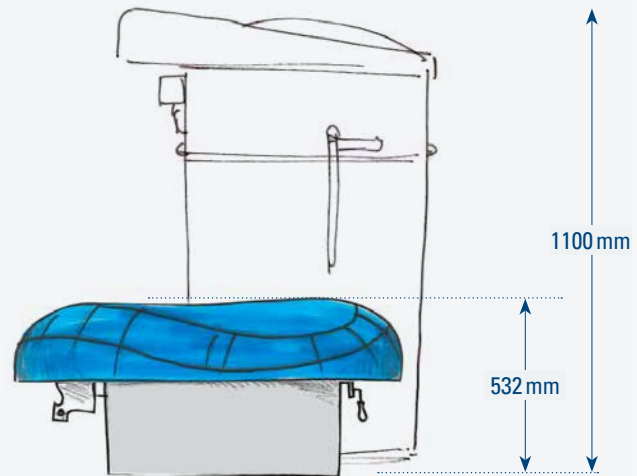

Unlike traditional silo venting solutions, the PowerCore SVU cover remain safely accessible.

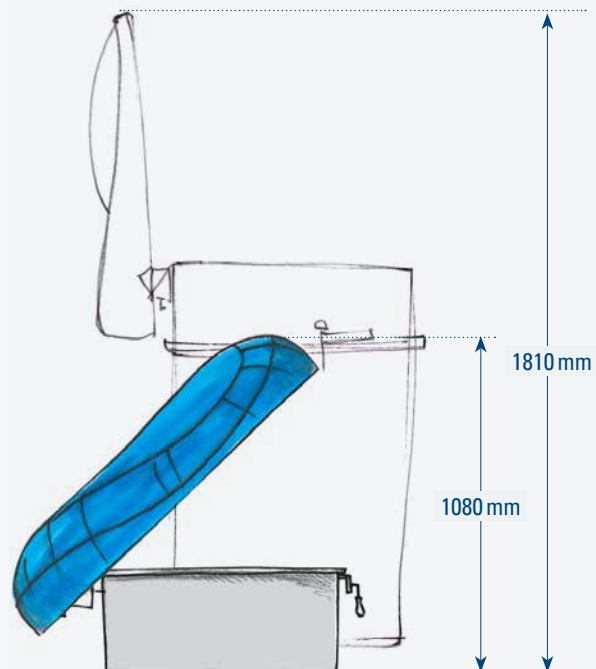

CHANGING EXPECTATIONS

The performance, reliability, and ergonomics of the SVU is derived from a combination of advanced filtration technology, unique form factors and high performance reverse jet cleaning to ensure effective dust release and a continuous level of operation for longer. Fewer filters, better cleaning, and shorter maintenance leads to major cost savings over the life of the collector.



DESIGNED WITH SAFETY IN MIND

- Compact, low height design for easy and safe filter access and maintenance
- Up to 54% shorter than conventional venting units (532 mm)
- Safe cover operations due to its low height



ROBUST AND WEATHER PROOF

- Robust Stainless Steel Body
- Controller, diaphragm valves, and pressure switch are safely protected under the weather hood
- Integrated mounting Flange



EASY INSTALLATION

- Fully assembled
- Removable lifting hooks
- Pre set controller
- Mounting Flange DN800mm



EFFECTIVE FILTER CLEANING

- Reverse pulse jet cleaning
- Effective dust dislodging
- No filters bridging risks



FAST & CONVENIENT MAINTENANCE

- Low profile for easy access
- Top-removal filters packs
- No tools required
- Hood fitted with twin gas struts for easy open and close

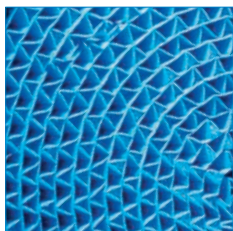

POWERCORE® WITH ULTRA-WEB® TECHNOLOGY

- High efficiency (78% fewer emissions)
- Long filter life
- Enhanced filtration performance 2 PowerCore® CP packs replace up to 6 traditional bags



*Independent lab results obtained using ASTM D6830-02 per EPA PM 2.5 performance verification. Compared to Standard Polyester Bags. Annual emissions calculated assuming 26.461 m³/h (14,400 cfm) airflow rate, 265 working days per year, and two shifts per day. Field measurements may vary due to differences in dust contaminant and sensitivity of measurement equipment.

POWERED BY POWERCORE®

At the core of the SVU unique design is PowerCore the most innovative filtration technology from Donaldson is integral to the dramatic downsizing of the PowerCore SVU series.

An entirely new approach to dust collectors, the PowerCore filter pack is small, lightweight, and easily handled by one person.

Donaldson's PowerCore technology combined to our well-proven Ultra-Web advanced fine fiber technology allows more effective filter area to be packaged in a smaller space:

Pneumatic Silo Venting applications typically requiring up to 6 filter bags (24 m²) in the past now only needs 2 PowerCore compact filter packs. With more media packed into a smaller space and a simplified airflow path, PowerCore filter packs provide high performance with a low pressure drop.

POWERCORE® SVU SERIES

- High performance in a smaller package
- Extended maintenance intervals
- Fast, safe & easy maintenance
- Lower shipping, installation and maintenance costs
- Technology proven in field applications for more than 10 years



2 POWERCORE
FILTER PACKS
*replaces
up to* **6**
FILTER BAGS

ADVANCED FILTRATION TECHNOLOGY

Fluted channels are alternately sealed allowing air to enter through an open flute and forcing it to exit out an adjacent flute

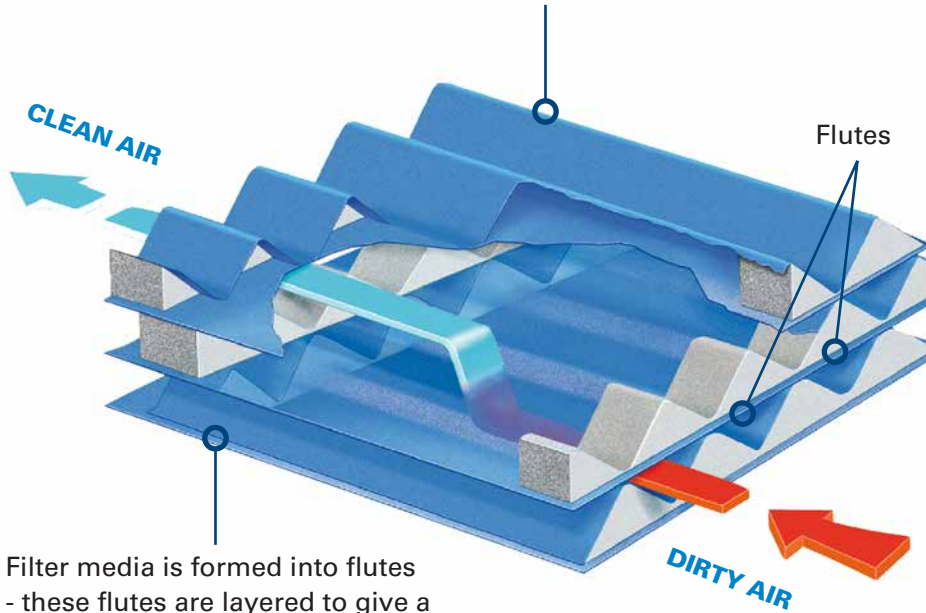

Filter media is formed into flutes - these flutes are layered to give a tight, rugged structure to the filter



SPECIFICATIONS

CASING

Max. height above silo	When closed: 532 mm When open: 1,080 mm
Plan	1,150 mm x 935 mm
Mounting Flange	DN 800 mm
Weight	65 kg
Design Pressure	± 5,000Pa
Colour	Cover: Blue Body: Stainless Steel
Outdoor, weather protection	UV protection
Dirty side contact parts	Stainless steel
Construction	Welded and bolted assembly



CLEANING SYSTEM

Type	Reverse pulse jet
Compressed air pressure	6 bar (max)
Compressed air consumption	22 NI per pulse
Compressed air quality	Class 3 (ISO 8573-1)
Integrated controller	STR2 – Cycle timer
Input voltage	230/115VAC

PERFORMANCE

Nominal airflow	177 cfm / 2,000 m ³ /hr
Emission level	<5 mg / m ³
Noise Level	<80 dB(A) (ISO 3744)
Temperature specification	-10° to + 60°C

FILTERS ELEMENTS

Filters elements	PowerCore® CP
Number of elements	2
Filter pack dimensions	L 569 x W 193 x H 178 mm



DIMENSIONS

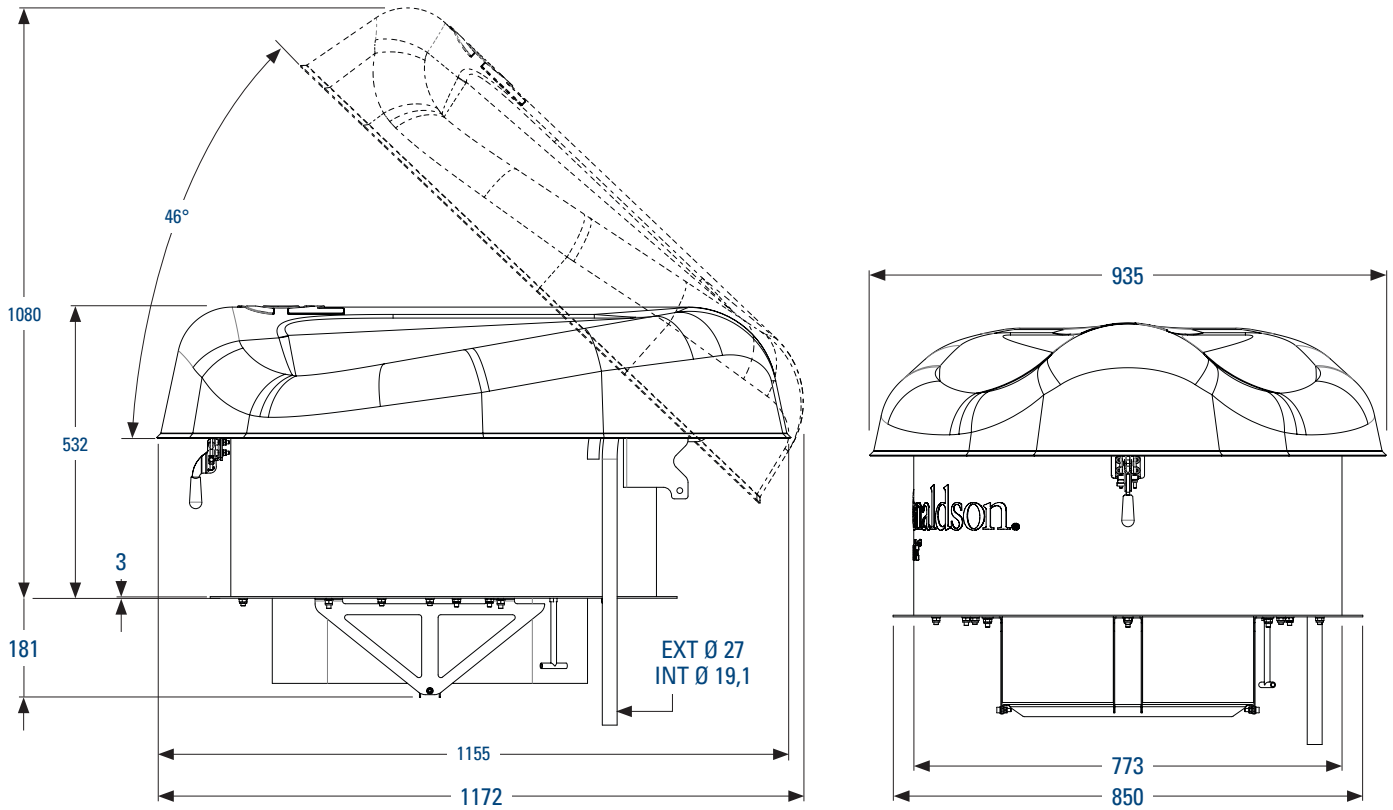

PRODUCT	DESCRIPTION	PART NUMBER
Silo Venting Unit	Silo Venting Unit (SVU) + 2 PowerCore® CP UWSB filter packs	FAAM04945
PowerCore® CP filter packs	Ultra-Web Spunbond (UWSB) Ultra-Web Antistatic (UWAS)	2626460 P032643



Industry-Leading Technology

- Advanced filtration technology for optimal performance
- Reduced energy consumption and cost of ownership
- Advanced design and testing capabilities

The Most Filters and Parts

- For every brand and style of collector
- Wide range of filtration media for any application
- 90,000 filters and parts in stock and ready to ship

Unparalleled Support

- Live technical specialists
- Comprehensive pre- and post-sale support
- 40 manufacturing plants and 14 distribution centers worldwide

Significantly improve the performance of your collector with genuine Donaldson Torit replacement filters and parts. **Call Donaldson Torit at 800-365-1331.**

Important Notice

Many factors beyond the control of Donaldson can affect the use and performance of Donaldson products in a particular application, including the conditions under which the product is used. Since these factors are uniquely within the user's knowledge and control, it is essential the user evaluate the products to determine whether the product is fit for the particular purpose and suitable for the user's application. All products, product specifications, availability and data are subject to change without notice, and may vary by region or country.



Donaldson.

Donaldson Company, Inc.
Minneapolis, MN
donaldson.com • shop.donaldson.com

North America
Email: donaldson@donaldson.com
Phone: (USA): +1-800-365-1331 • (MX): +1-800-343-36-39

Australasia
Email: marketing.australia@donaldson.com
Phone: +61-2-4350-2000
Toll Free: (AU) +1800-345-837 • (NZ) +0800-743-387

F118016NA ENG (3/21) PowerCore Silo Venting Collectors - SVU Series ©2020-2021 Donaldson Company, Inc.
Donaldson, Torit, PowerCore, and the color blue are marks of Donaldson Company, Inc. All other marks belong to their respective owners.

China
Email: info.cn@donaldson.com
Phone: +86-400-820-1038

Donaldson Europe B.V.B.A.
Email: IAF-europe@donaldson.com
Phone: +32-16-38-3811

India
Email: info.difs@donaldson.com
Phone: +91-124-4807-400 • +18001035018

Japan
Email: jp-ndli.ifsw@donaldson.com
Phone: +81-42-540-4112

Korea
Email: iaf-kr@donaldson.com
Phone: +82-2-517-3333

Latinoamerica
Email: IndustrialAir@donaldson.com
Phone: +52-449-300-2442

South Africa
Email: SAMarketing@donaldson.com
Phone: +27-11-997-6000

Southeast Asia
Email: IAFSEA@donaldson.com
Phone: +65-6311-7373