

Donaldson.
Torit®

WSO MIST COLLECTORS



Synteq XP™

MEDIA TECHNOLOGY
FOR MIST COLLECTION



THE ONLY MIST COLLECTOR YOU NEED

The versatile Donaldson® Torit® WSO Mist Collector provides three filter solutions for water-soluble coolant, straight oil, and the most challenging, oily smoke. The WSO uses revolutionary Synteq XP™ Media Technology engineered for superior draining, resulting in lower pressure drop and longer filter life.

The WSO can be modified with a simple filter change, leading to leaner operation, cost savings and cleaner plant air.

WSO OFFERS:

- 3 in 1 solutions for mist applications
- Advanced Synteq XP™ high efficiency media
- Cross-flow design for better drainage
- Easy to change cartridge filters
- Energy savings
- Continuous-duty design
- Lower life cycle costs
- Quiet operation
- Configurations for machine mounting, floor stands, or ducted central systems
- UL-approved electrical components
- 10-year warranty

3 APPLICATIONS 1 COLLECTOR



3 SOLUTIONS



WSO 15
with optional
3rd-stage
HEPA filter

THE WSO DIFFERENCE

The WSO mist collector can be configured to meet your facility's requirements: machine mountable, floor-mounted stand, and ducted cellular and central systems.

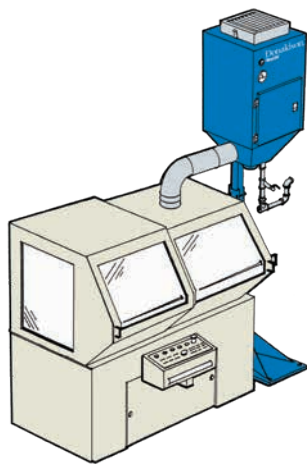

WSO 15
floor-mounted stand with
afterfilter on a horizontal
machining center.

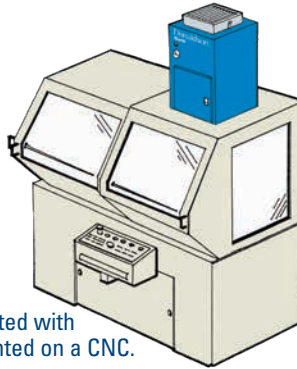

WSO 10
machine mounted with
afterfilter mounted on a CNC.

OVER 40 YEARS
OF MIST EXPERIENCE

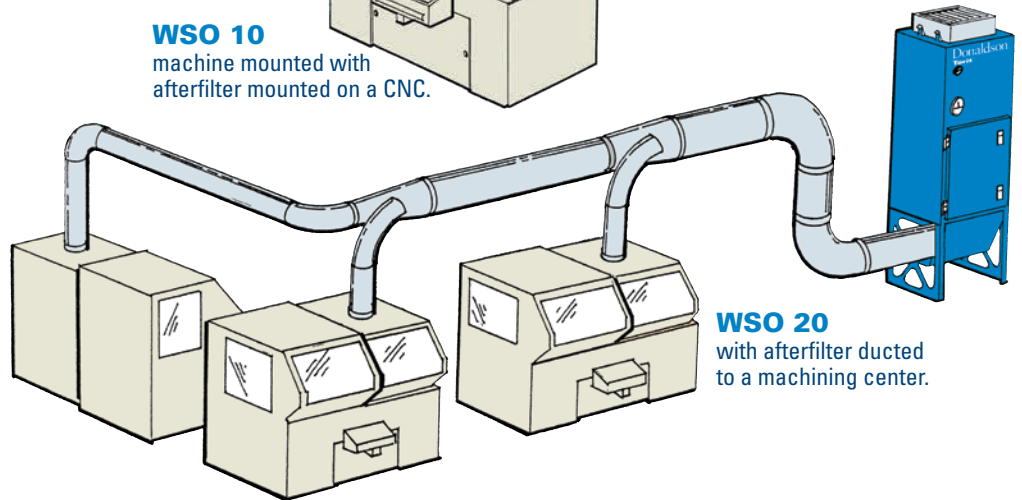

WSO 20
with afterfilter ducted
to a machining center.

75,000+ MIST COLLECTORS
INSTALLED

EASY FILTER MAINTENANCE



Differential pressure
gauge(s) identifies
filter maintenance.



One pivot lever
securely retains the
primary filter element.



Filter is easily removed.



Simplified servicing
means less maintenance
time and cost.

VERSATILE IN APPLICATION, FLEXIBLE IN DESIGN

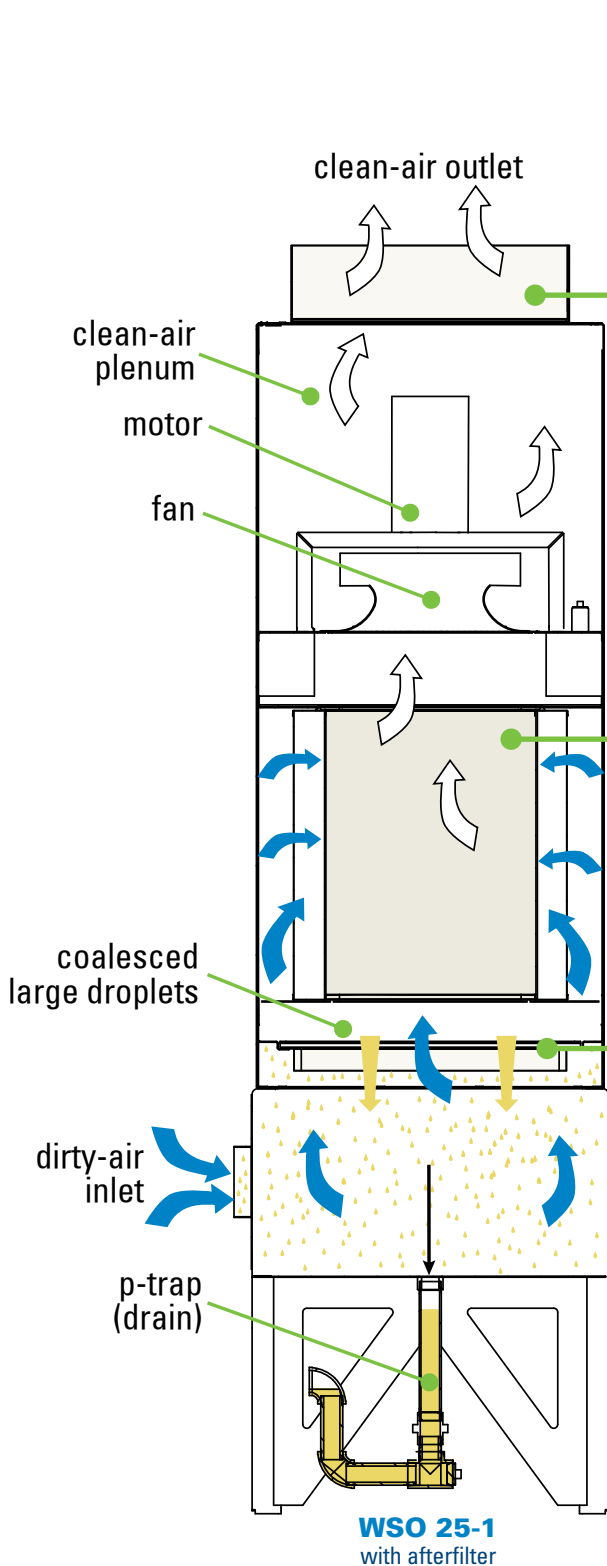

3RD STAGE:

Final Filter (Optional)

- **DOP**
95% efficient on 0.3 micron mist and smoke
- **HEPA**
99.97% efficient on 0.3 micron mist and smoke



2ND STAGE:

Primary Filter (select one)

- **Synteq XP - W**
 - For mist from water-soluble coolant
 - Economical, fast draining, for heavy water-based liquid load
- **Synteq XP - S**
 - For smoke from machining
 - Highest efficiency for challenging applications
- **Synteq XP - O**
 - For mist from straight oil machining
 - Efficiency designed for small oil aerosols



1ST STAGE:

Prefilter Options (select one)

- **Metal Screen**
For heavier dust/grit from wet grinding
- **Metal Mesh**
For most water-soluble mist
- **Polypropylene Mesh**
For most straight oil mist
- **High Efficiency 1st Stage**
For oily smoke



OBLONG CARTRIDGES OUTPERFORM TRADITIONAL FILTERS



WSO OBLONG FILTER SHAPE FEATURES:

- Up to 45% more filter surface area than pocket filters and round cartridges
- Best fit in rectangular cabinet
- Lower pressure drop
- Longer filter life

CROSS-FLOW FILTER DESIGN

Cross-flow filter design for better drainage means longer filter life. Dirty air flows horizontally through the walls of the WSO filter, perpendicular to drainage of collected and coalesced mist. This design promotes optimum drainage, which extends filter life and returns collected coolant for re-use. Conventional mist collectors have an upflow design impeding drainage and causing short filter life.

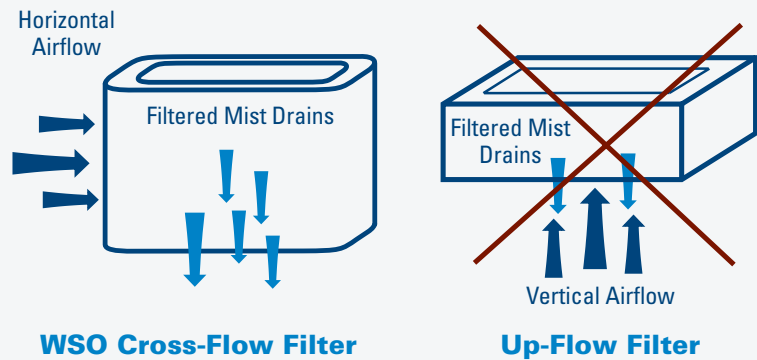

CHOOSE THE BEST FILTER FOR YOUR APPLICATION



WATER SOLUBLE
Typical particle size: 2-20 micron

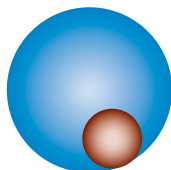

- Largest mist particles
- 99.8%* removal efficiency



SMOKE
Typical particle size: 0.07-1.2 micron



- Smallest aerosols from machining
- 99.97%** removal efficiency



OIL
Typical particle size: 0.8-5 micron

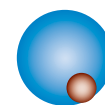

- Submicron oil mist
- 99.5%* removal efficiency

* Stated efficiency typical for water-soluble and straight oil applications. The use of 95% DOP or HEPA filter may be required.

** Stated efficiency typical for oily smoke application using a HEPA final filter

ADVANCED FILTER MEDIA FOR MIST

Proprietary Synteq XP Media Technology is a revolutionary new media for mist collection that provides high efficiency, low operating pressure drop, and long filter life when compared to traditional media.

This photo from our Scanning Electron Microscope and the illustration show why Synteq XP Media Technology provides superior performance on mist collection applications.

SYNTEQ XP MEDIA TECHNOLOGY WITH RESIN-FREE, BINDING FIBERS

- Engineered blend of small and large fibers, with proprietary, resin-free bonding system
- Small fibers are scientifically proven to increase efficiency
- Large fibers provide structural support and clear drain channels
- Proprietary bonding system stabilizes pore structure for optimum performance

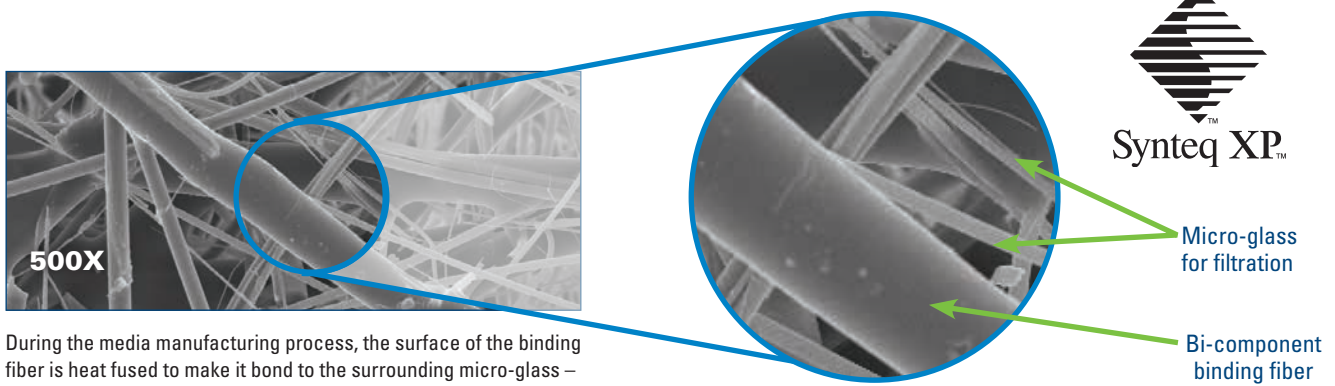

During the media manufacturing process, the surface of the binding fiber is heat fused to make it bond to the surrounding micro-glass – no resin webbing to block pores.

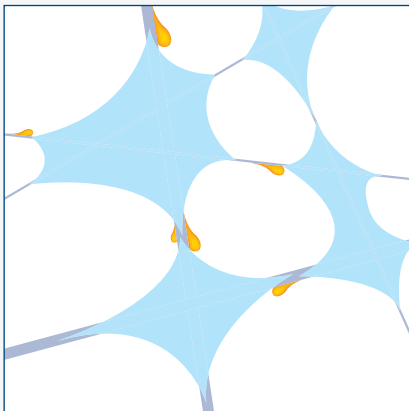

Traditional Mist Cartridge Media (with Resins)

- Made with resins to bond fibers
- Resins reduce air pathways and block drainage

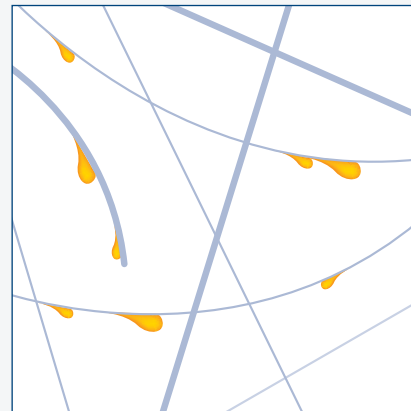

Traditional Mist Panel Filter Media (Loose Fibers)

- Four-layer media structure without fiber bonding
- Fibers sag under weight of oil
- Fiber movement creates larger holes that pass oil

SYSTEM CURVES FOR WSO

POWERFUL PERFORMANCE

Unlike other products that require upgrades for more demanding applications, each WSO comes standard with a unique high performance fan. The system curves below indicate available external static pressure to the unit with clean filters.

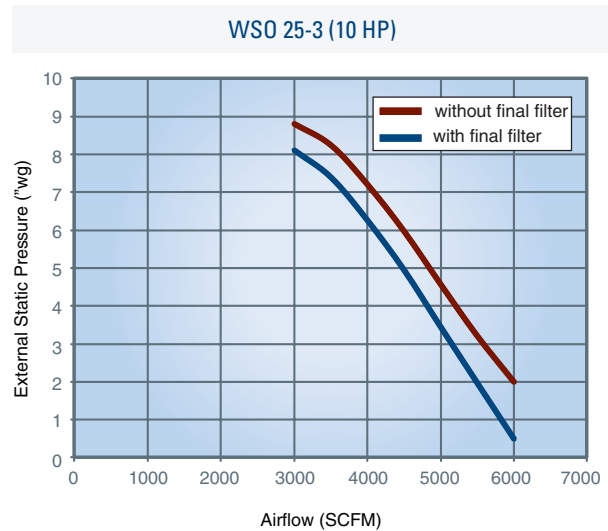
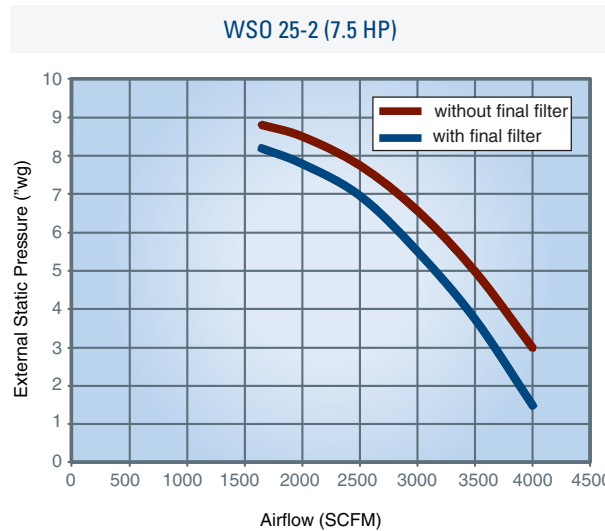
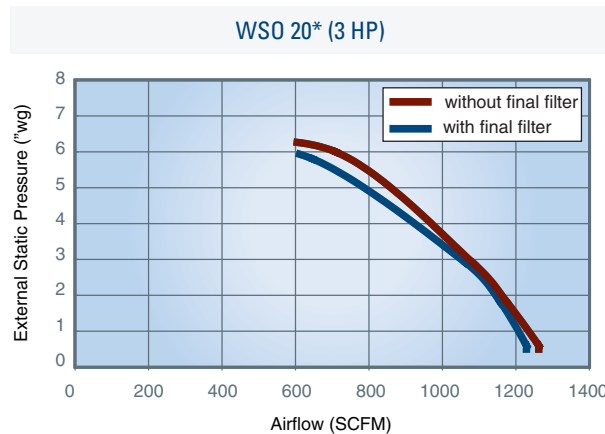
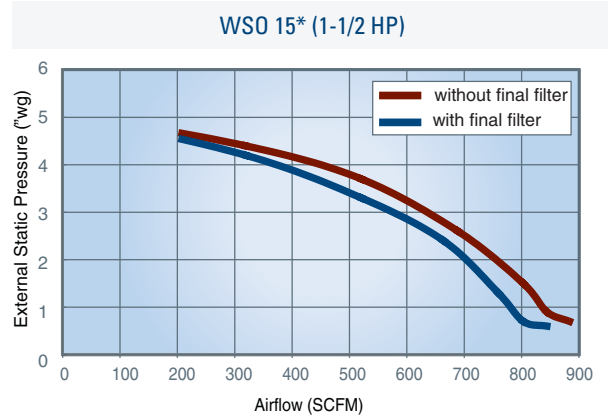

* WSO 10, 15, 20, and 25-1 have integral power packs (motor and fan).

DIMENSIONS & SPECIFICATIONS

WSO 10, 15, 20

Machine Mounted (MM)

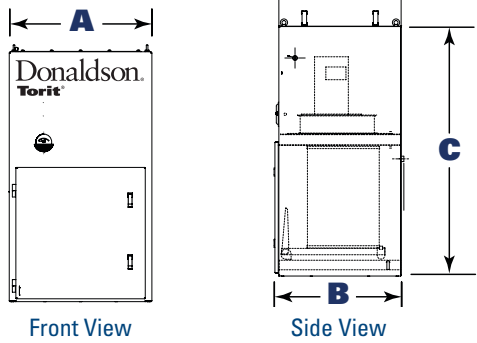

WSO 25-2, 25-3

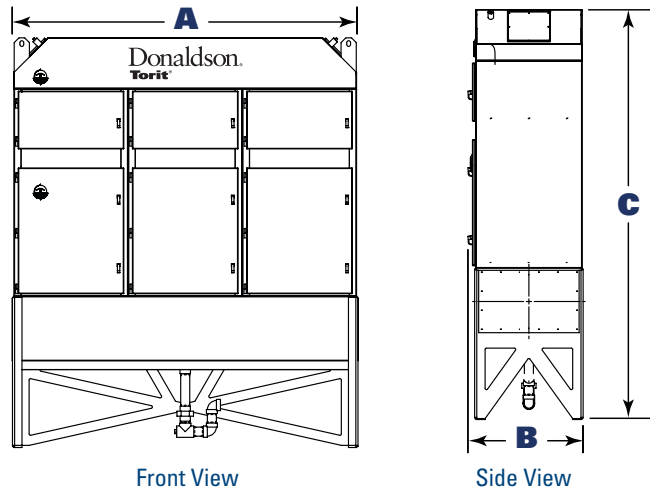

WSO 20, 25-1

Floor Mounted (FM)

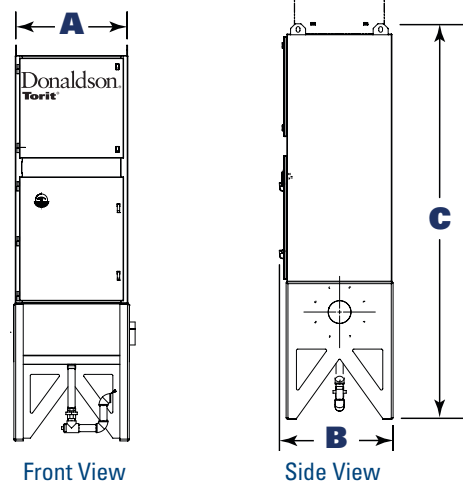

Models	Nominal Airflow*		No. of Filters	Filter Height		Filter Area						Motor (hp)	Shipping Weight		Dimensions								Sound Level** dB(A)	
						Water		Oil		Smoke					A		B		C without Afterfilter		C with Afterfilter		without Afterfilter	with Afterfilter
	cfm	m ³ /h		in	mm	ft ²	m ²	ft ²	m ²	ft ²	m ²		lb	kg	in	mm	in	mm	in	mm	in	mm		
WSO 10	450	764	1	10	254	50	4.6	43	4.0	—	—	¾	180	81.6	19.0	482.6	20.9	530.9	33.2	843.3	36.5	927.1	66	63
WSO 15	850	1444	1	15	381	125	11.6	109	10.1	85	7.9	1½	250	113.4	24.0	609.6	24	609.6	41.2	1046.5	44.5	1130.3	70	68
WSO 20	1230	2089	1	20	508	167	15.5	146	13.6	113	10.5	3	285	129.3	28.0	711.2	26	660.4	49.1	1247.1	60.6	1539.2	70	68
WSO 20 (FM)	1230	2089	1	20	508	167	15.5	146	13.6	113	10.5	3	385	174.6	28.0	711.2	26	660.4	85.2	2164.1	96.6	2453.6	70	68
WSO 25-1	1850	3143	1	25	635	286	26.6	245	22.8	195	18.1	3	750	340.2	30.8	782.3	30.3	769.6	105.4	2677.2	114.3	2903.2	71	69
WSO 25-2	3700	6285	2	25	635	572	53.1	490	45.5	390	36.2	†	1000	453.6	60.8	1544.3	30.3	769.6	107.7	2735.6	107.6	2733.0	†	†
WSO 25-3	5550	9428	3	25	635	858	79.7	735	68.3	585	54.3	†	1330	603.3	90.8	2306.3	30.3	769.6	107.7	2735.6	107.6	2733.0	†	†

* Based on clean filters.

** Published dB(A) sound pressure levels were made in a hemi-anechoic chamber. Units were run with clean filters and maximum airflow through approximately 10 feet (3 meters) of ducting connected to an inlet plenum. Measurements were made 1.5 meters off the ground, 1 meter away from the collector, on the filter door side of the mist collector. Actual installed equipment sound pressure levels will vary depending upon the measurement location, the operating conditions, the installation, and the surrounding environment.

† Optional fans available. See optional fan specifications for sound level data.

FEATURES & EQUIPMENT OPTIONS

COLLECTOR DESIGN [†]	WSO MODELS*					
	10, 15, 20		20, 25-1		25-2, 25-3	
	STD	OPT	STD	OPT	STD	OPT
Mild Steel Construction	X		X		X	
Inlet Hopper with Collar		X	X		X	
Inlet Hopper with Legs		X		X		X
Inlet Hopper with Vibration Isolators		X				
Integral Power Packs	X		X			X
Machine Mount	X					
Ceiling Mount		X				
Floor Mount		X	X		X	
P-Trap Assembly		X		X		X
Drain Collection Container		X		X		
Flex-Duct		X				
FILTERS						
First-Stage Wire Mesh	X		X		X	
First-Stage Polypropylene Mesh		X		X		X
High Efficiency First-Stage		X		X		X
Synteq XP for Water Soluble	X		X		X	
Synteq XP for Straight Oil		X		X		X
Synteq XP for Smoke		X		X		X
Third-Stage HEPA Filter		X		X		X
Third-Stage 95% DOP Filter		X		X		X
PAINT SYSTEM						
Textured Multi-Coat Paint Finish with 2,000-Hour Salt Spray Performance	X		X		X	
Custom Color		X		X		X
ELECTRICAL CONTROLS, GAUGES & ENCLOSURES						
Minihelic ^{***} Gauge	X					
Magnehelic ^{***} Gauge			X		X	
IEC Motor Starter		X		X		X
Type 12 (NEMA & UL) Motor Starter		X		X		X
Junction Box - Mounted & Prewired		X		X		
Remote Start/Stop		X		X		X
Machine Tool Interlock		X		X		X
Mounted and Prewired Motor Starters		X				
WARRANTY						
10-Year Warranty	X		X		X	

[†] Donaldson Torit equipment is designed to IBC guidelines for specific wind speed exposure and seismic spectral acceleration at grade level. Contact your Donaldson Torit representative for detailed information available on the equipment's Spec Control drawings. Equipment may be customized to meet unique, customer-specified site requirements.

* Custom size units larger than WSO 25-3 are also available.

** Minihelic and Magnehelic are registered trademarks of Dwyer Instruments, Inc.

PROVEN PERFORMANCE ON HUNDREDS OF APPLICATIONS



WSO on Oil Mist

20,000 cfm (33,973 m³/h)



WSO - Horizontal Grinder

850 cfm (1,444 m³/h)



WSO on Cold Forming

1,200 cfm (2,038 m³/h)



WSO - Machining Center

1,200 cfm (2,038m³/h)

DONALDSON® TORIT® CLEARSTHE SMOKE AT UNITED GEAR & ASSEMBLY

The WSO Mist Collector Dramatically Reduces Oily Smoke

INDUSTRY:	Machining
PROBLEM:	Excessive smoke generated from hobbers during the gear production process
SOLUTION:	Donaldson Torit WSO Mist Collector significantly reduced the amount of smoke in the plant, maintenance time, and cost

How many gear hobbers does it take to fill a 24,000 square foot room with smoke in less than 20 minutes? Just one.

United Gear & Assembly, Inc. (UGA) manufactures gears and shafts for motors, generators, transmissions and drive trains used by OEM manufacturers worldwide, including custom gear and shaft products designed to meet rigid specifications. The company's Hudson, Wisconsin manufacturing plant needed to reduce the amount of smoke generated from its hobbers during the gear production process.

Hobbing is a multipoint machining process in which gear teeth are progressively generated by a series of cuts with a helical cutting tool called a hob. Gear hobbing uses sulfuric oil, which generates a high degree of smoke. Dry hobbing, while cutting down on the amount of oil used, still generates excessive smoke when the gears are cleaned with compressed air.

"We run a lot of short jobs right now, which include 300 – 5,000 parts per month per machine," said Tom Huppert, in charge of maintenance at United Gear & Assembly, Inc. "The sulfuric oil used in our gear hobbers was generating too much smoke – our facility was filling up in just a few minutes. And while our dry hobbers use less oil, they also generated a lot of smoke. Our people were complaining, and we needed a way to stop it."

UGA installed its first Donaldson® Torit® WSO Mist Collector two years ago and achieved immediate success. The WSO provides filter solutions for the three mist categories: water-soluble coolants, straight oil, and the most challenging— oily smoke. It can be configured to meet specific facility

requirement, including machine mount, stand mount for a single machine, and ducted cellular and central systems.

"We mounted a WSO-15 right on our gear hobber and it did the trick," continued Huppert. "We had tried other collectors. They vibrated too loudly, their filters had to be changed too often – which added to our cost – or parts and service were not immediately available to us. The Donaldson WSOs have far met our expectations in all levels of performance."

The WSO uses revolutionary Synteq XP™ Media Technology, which blends small and large fibers with a proprietary, resin-free bonding system that provides high efficiency, low operating pressure and long filter life when compared to traditional filters.

“ We mounted a WSO-15 right on our gear hobber and it did the trick, continued Huppert. We had tried other collectors. They vibrated too loudly, their filters had to be changed too often – which added to our cost – or parts and service were not immediately available to us. The Donaldson WSOs have far met our expectations in all levels of performance. ”

Tom Huppert,
United Gear & Assembly, Inc.

"The WSO mist collector has been running for two years and we've only had to change the filter once," said Huppert. "For the amount of smoke our hobbers generate, that's better than we expected. Both our maintenance time and cost have been significantly reduced, and our employees are no longer complaining about the smoke in our facility."

Today UGA has six Donaldson Torit WSO mist collectors and plans to add more.

Industry-Leading Technology

- Advanced filtration technology for optimal performance
- Reduced energy consumption and cost of ownership
- Advanced design and testing capabilities

The Most Filters and Parts

- For every brand and style of collector
- Wide range of filtration media for any application
- 90,000 filters and parts in stock and ready to ship

Unparalleled Support

- Live technical specialists
- Comprehensive pre- and post-sale support
- 40 manufacturing plants and 14 distribution centers worldwide

Significantly improve the performance of your collector with genuine Donaldson Torit replacement filters and parts. **Call Donaldson Torit at 800-365-1331.**

Important Notice

Many factors beyond the control of Donaldson can affect the use and performance of Donaldson products in a particular application, including the conditions under which the product is used. Since these factors are uniquely within the user's knowledge and control, it is essential the user evaluate the products to determine whether the product is fit for the particular purpose and suitable for the user's application. All products, product specifications, availability and data are subject to change without notice, and may vary by region or country.



Donaldson.

Donaldson Company, Inc.
Minneapolis, MN
donaldson.com • shop.donaldson.com

North America
Email: donaldson@donaldson.com
Phone: (USA): +1-800-365-1331 • (MX): +1-800-343-36-39

Australasia
Email: marketing.australia@donaldson.com
Phone: +61-2-4350-2000
Toll Free: (AU) +1800-345-837 • (NZ) +0800-743-387

F118045 ENG (02/20) WSO Mist Collector Brochure ©2006-2020 Donaldson Company, Inc.
Donaldson, Torit, Synteq XP and the color blue are marks of Donaldson Company, Inc. All other marks belong to their respective owners.

China
Email: info.cn@donaldson.com
Phone: +86-400-820-1038

Donaldson Europe B.V.B.A.
Email: IAF-europe@donaldson.com
Phone: +32-16-38-3811

India
Email: info.difs@donaldson.com
Phone: +91-124-4807-400 • +18001035018

Japan
Email: jp-ndl.ifsw@donaldson.com
Phone: +81-42-540-4112

Korea
Email: iaf-kr@donaldson.com
Phone: +82-2-517-3333

Latinoamerica
Email: IndustrialAir@donaldson.com
Phone: +52-449-300-2442

South Africa
Email: SAMarketing@donaldson.com
Phone: +27-11-997-6000

Southeast Asia
Email: IAFSEA@donaldson.com
Phone: +65-6311-7373