

Donaldson.
Torit®

TORIT® POWERCORE®
DUST COLLECTORS
VH SERIES

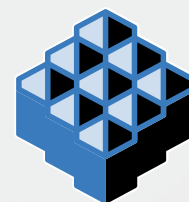

PowerCore®
A Donaldson Filtration Technology

SMARTER, SMALLER COLLECTORS

On every measurable scale, Torit® PowerCore® dust collectors outperform traditional baghouse and cartridge collectors. The new VH series is smaller and much more cost-effective. And, from installation until the day it retires, it is so easy to use and maintain, you will never have to think twice about your Torit PowerCore dust collector.



(13,600 cfm collectors)
Torit PowerCore VH 2-8
vs. Traditional (162) 8-ft
Filter Baghouse

Smaller Footprint

Up to 70% smaller footprint clears space for other equipment.

Shorter

Lower clearance height fits in more low headroom applications and reduces transportation costs.

More Durable

Each PowerCore dust collector is built to the demanding standards you expect from Donaldson® Torit®. Its heavy-gauge steel and all-welded design withstands abrasive dust and harsh external environments. Plus, the chance of filter abrasion is greatly reduced due to the collector and filter design. Single air inlets/outlets reduce ducting and installation costs. And, of course, Donaldson Torit stands by the VH Series with strong technical support, 24-hour replacement filter shipping, and a 10-year warranty.

Lower Total Cost of Ownership

Fewer filters. Less downtime. Lower shipping costs. It all adds up to major cost savings over the life of the collector.



Easy Filter Replacement

Changing filters requires no special tools or entering confined spaces, and downtime is held to a minimum.

Fewer Filters

PowerCore filter packs save you money with every filter change.

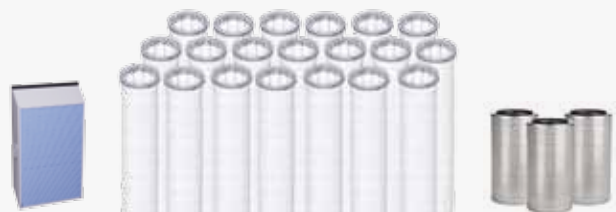

One PowerCore filter pack replaces up to twenty 8' bag filters or three cartridge filters.

MINING AND METALWORKING DUST HAS MET ITS MATCH

The VH Series brings the performance and simplicity of PowerCore technology to the mining and metalworking markets. Available for indoor and outdoor applications from 5,000 to 50,000 cfm, the VH series is specially designed to handle the heavy and abrasive dust loads found in:

MINING



Crushing
Classifying
Screening
Material Handling
Blending
Mixing

METALWORKING

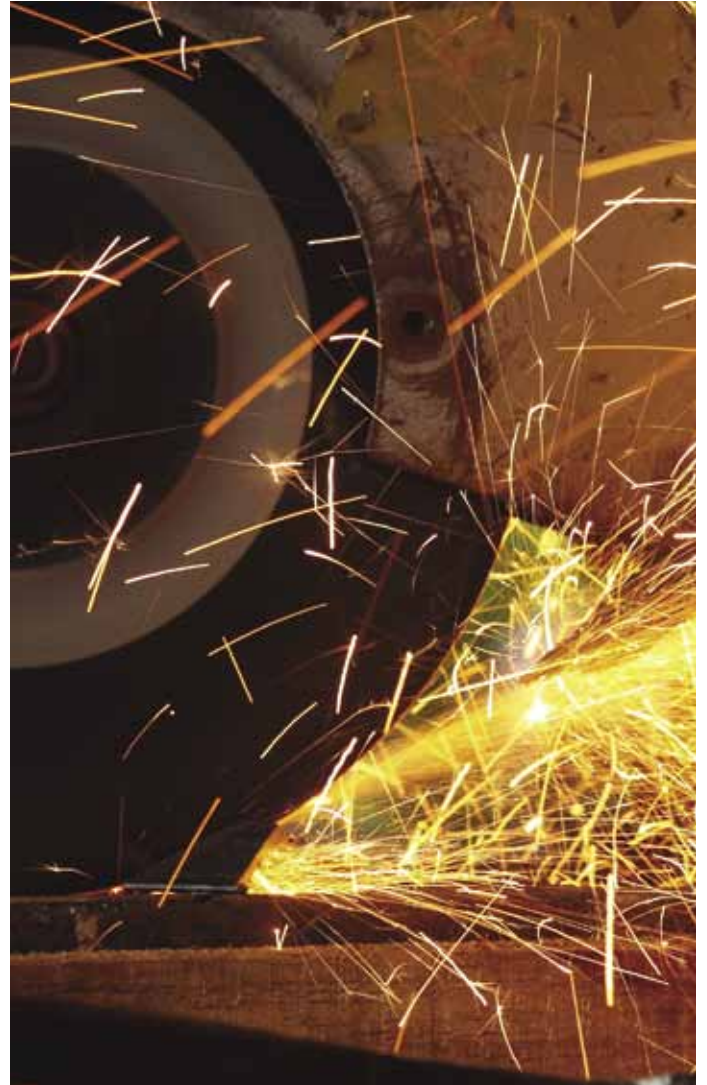

Grinding
Blasting

THE NEW STANDARD IN DUST COLLECTION

It's not a cartridge. It's not a bag. PowerCore filter packs take proprietary Ultra-Web® nanofiber filter media and form it into flutes that collect particles without depth-loading.

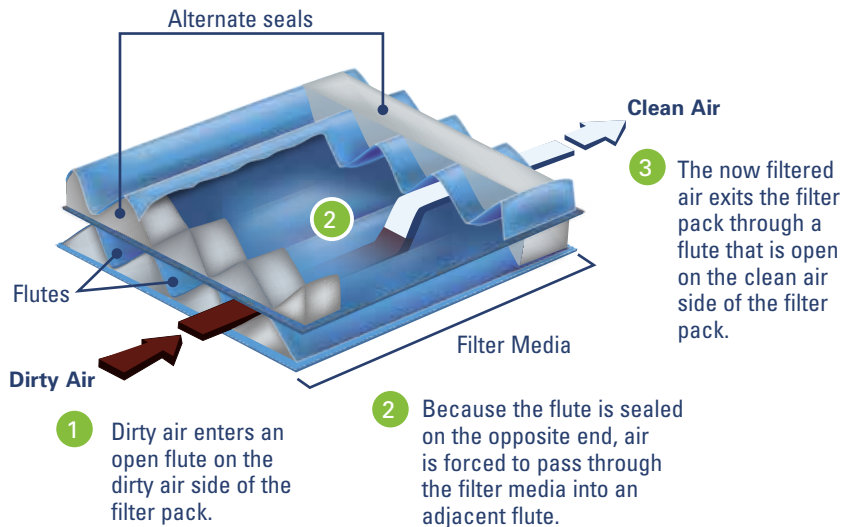
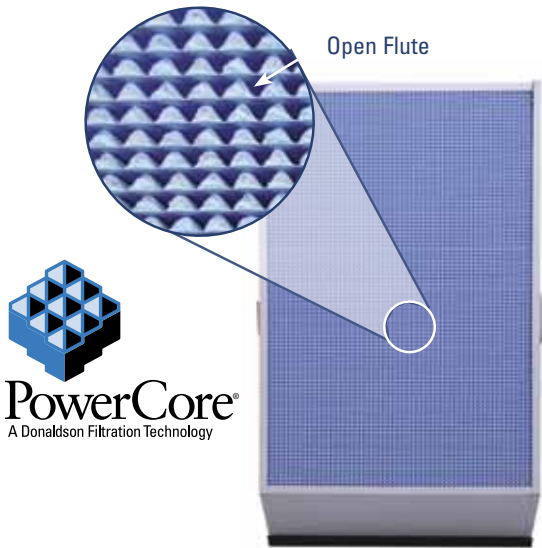

Ultra-Web Technology

PowerCore filter packs employ Donaldson Torit's proprietary Ultra-Web nanofiber technology, and are backed by more than ten years of field tests.

Durable Ultra-Web nanofibers intercept even the smallest dust particles on the surface of the flutes. This surface-loading keeps the filter pack cleaner and improves the effectiveness of pulse cleaning, thus lowering both operational pressure drop and energy use.

Clean Ultra-Web Media

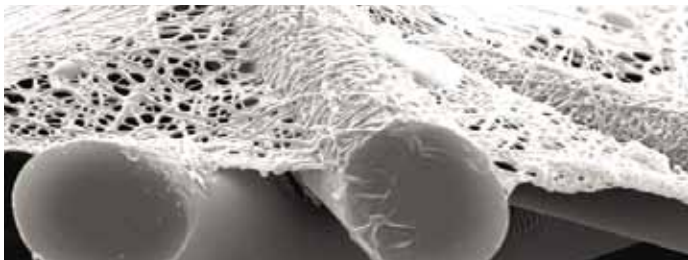

Surface-Loaded Ultra-Web Media (*substrate still clean*)

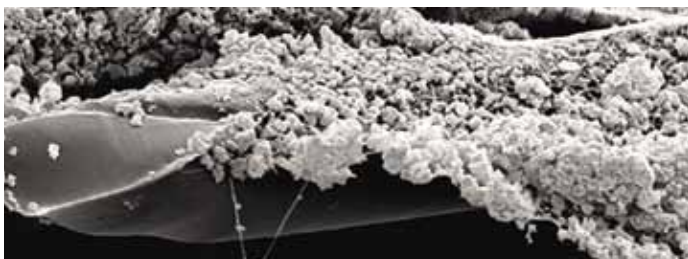

Lower Emissions with PowerCore Filter Packs

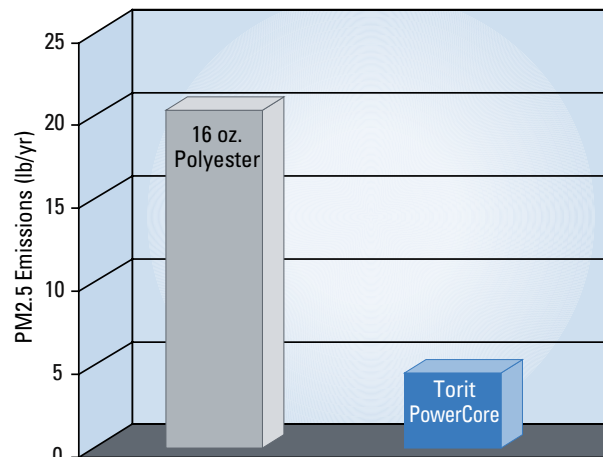

Independent lab results obtained using ASTM D6830-02 per EPA PM 2.5 performance verification.

78% FEWER EMISSIONS | **MERV 13**

The Torit PowerCore VH Series with PowerCore filter packs provides outstanding filtration efficiencies to help meet emission goals. PowerCore is rated MERV 13 and provides 78% fewer emissions than standard 16-ounce polyester bag filters.

INSIDE THE POWERCORE VH

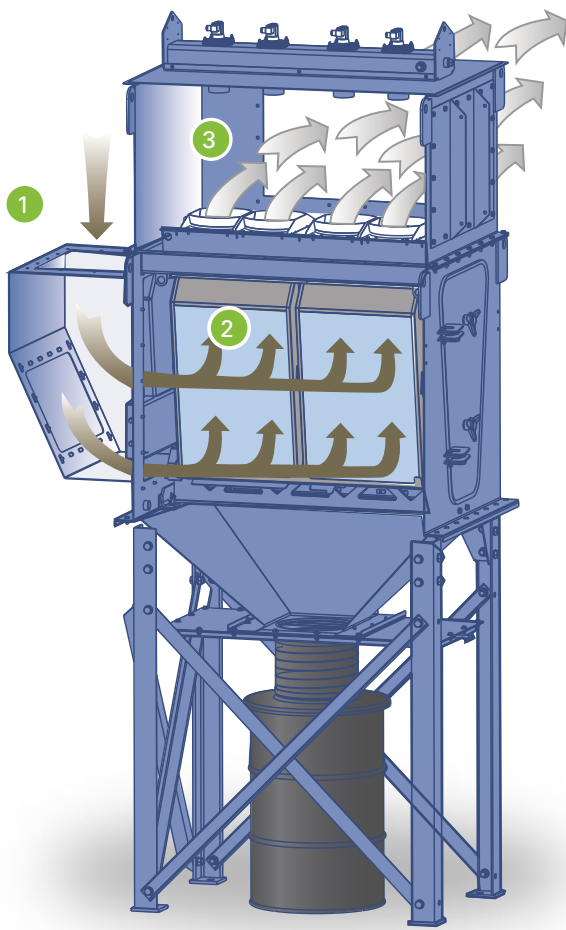

Standard Operation

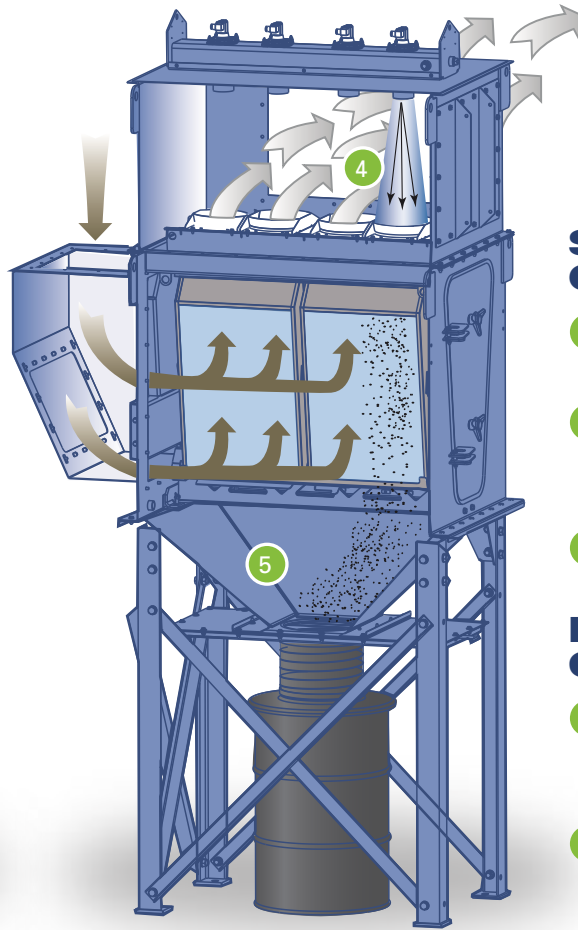

Pulse Cleaning

Standard Operation

- 1 Dirty air enters chamber
- 2 Air is pulled through filter media
- 3 Clean air exits

Pulse Cleaning

- 4 Pulsed air shoots directly into filter media
- 5 Dust particles are shot directly into the hopper

Zero-Turn Pulse Cleaning System

We call it Zero-Turn because the pulsed air is blown directly into the filters for maximum cleaning effectiveness. The V configuration of the PowerCore filter packs aligns the flutes in a near vertical formation allowing the dust to be pulsed directly into the hopper, preventing pulsed dust from being re-entrained on adjacent filter packs. Other collectors don't feature this directional alignment.

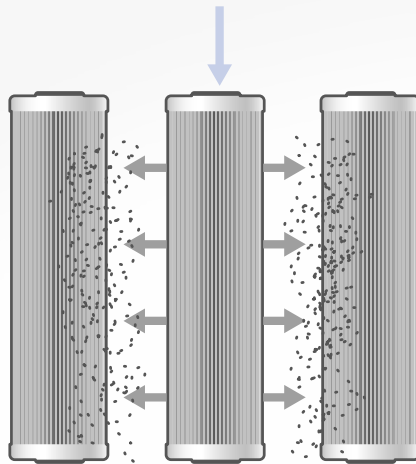

Other Collectors
Pulsed dust blows from filter to filter.

PowerCore Collectors
Pulsed dust is shot directly into the hopper.

QUICK CHANGE

Changing Torit PowerCore filter packs couldn't be easier. It's a one-person job and in a few minutes your operation is back up and running. A cartridge collector can't beat that. And a baghouse? Forget about it.

Labor Savings at Filter Changeout

	Numbers of Filters	Time to Replace (hrs)	Labor Rate (per/hr)	Labor Cost (per/hr)	Savings in Hours*	Labor Savings*
PowerCore VH Filter Packs	8	0.5	\$45	\$23	26.3	\$1,192
Traditional Bag Filters	162	27.0	\$45	\$1,215		
PowerCore VH Filter Packs	8	0.5	\$45	\$23	1.0	\$45
Traditional Cartridge Filters	24	1.5	\$45	\$68		

* Savings are based on one changeout. Calculations assume bags, cartridges, and PowerCore filter packs show equal life span; one person replacing one traditional bag filter in 10 minutes; one person changing PowerCore filter pack and cartridge in 3.75 minutes.



- 1 Open the quick-release hatch and lower the retention lever
- 2 Remove the first set of dirty filter packs
- 3 Slide out the tray and remove the second set of dirty filter packs
- 4 Insert new PowerCore filter packs and reverse the process

No special tools are required, and you never have to enter a confined space or dirty air plenum to do the job.

Considering a Baghouse? Think Again.

Baghouses had their day in the sun. They had a great run. If you really want one, Donaldson Torit offers the best in the business. But the fact is, the industry has evolved. PowerCore is the leading dust collector technology available today.

GAINS VALUE AS IT AGES

PowerCore VH Series dust collectors are a smart decision that looks even better over time. That's because it is an investment that keeps paying off the longer you use it. You save money on installation. You save money on changeouts. And its improved performance allows you to run your equipment with less filter changeout downtime for improved productivity.



Space Savings

A 40-70% smaller footprint frees up valuable floorspace.

Fewer Filters to Change

65-95% fewer filters to change dramatically cuts filter changeout costs related to labor and downtime.

Easier Changeouts

Side entry doors and no confined spaces make changing filter packs fast and easy.

Lower Emissions

Up to 78% fewer emissions than baghouses with traditional 16-ounce polyester bag filters.

Reduced Shipping Costs

Its smaller size reduces shipping, installation and accessory costs.

Improved Paint Performance

New paint tested to withstand a 2,000-hour salt spray keeps your Torit PowerCore dust collector looking good for years to come.

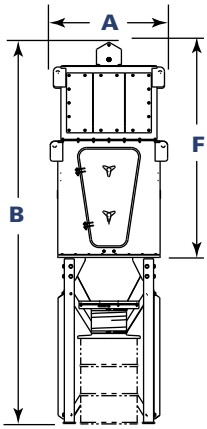

VH 1-4
front view
w/55 gal drum

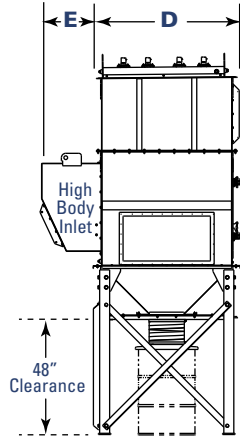

VH 1-4
left side view
w/55 gal drum

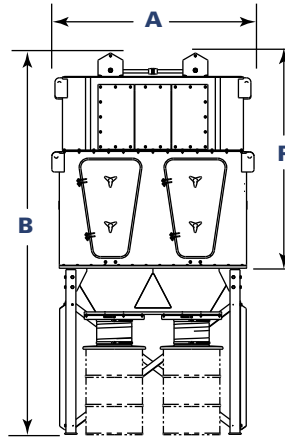

VH 2-8
front view
w/55 gal drum

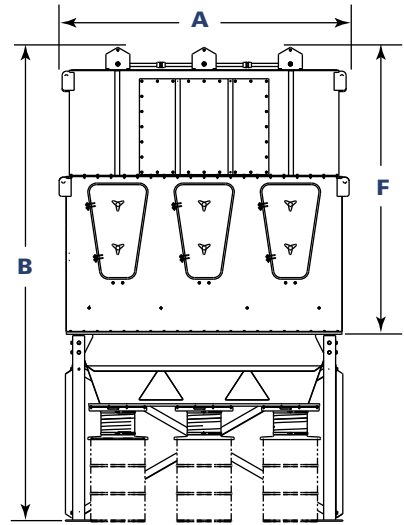

VH 3-18
front view
w/55 gal drum

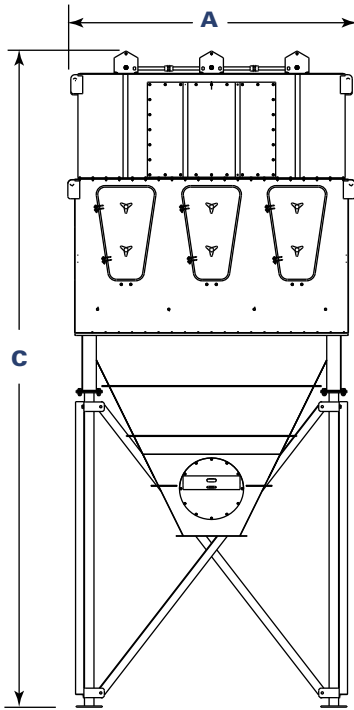

VH 3-18
front view
w/single outlet
60° hopper

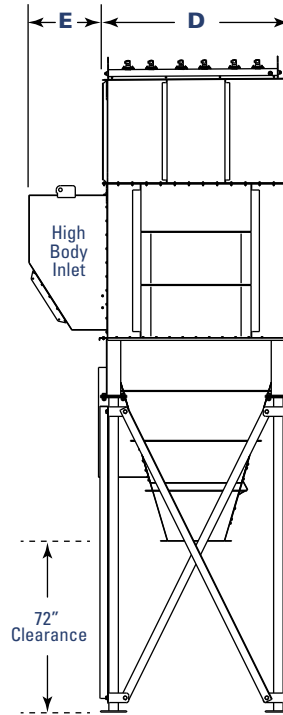

VH 3-18
left side view
w/single outlet
60° hopper

Dimensions & Specifications

Model	Dimensions (inches)					
	A	B*	C**	D	E	F
VH 1-4	44.5	152.8	187.3	56.5	21.9	85.3
VH 1-6	44.5	164.3	207.3	78.9	21.9	85.3
VH 2-8	78.5	152.8	204.3	56.5	21.9	85.3
VH 2-12	78.5	192.8	242.8	78.9	25.9	112.8
VH 2-16	82.5	—	265.8	101.3	30.9	118.8
VH 3-18	118.5	197.8	276.3	78.9	30.9	118.8
VH 2-20	N/A	N/A	N/A	N/A	N/A	N/A
VH 3-24	118.5	—	290.8	101.3	30.9	122.8
VH 3-30	N/A	N/A	N/A	N/A	N/A	N/A

* Height with 55 gallon drum.

** Height with 60° single rotary valve hopper.

Model	Nominal Airflow with High Body Inlet* (cfm)	No. of Filter Packs	Power Core Filter Area (ft ²)	No. of Doors	No. of Valves	Shipping Weight** (lbs)
VH 1-4	5,000 - 6,800	4	792	1	4	2,900
VH 1-6	6,800 - 10,200	6	1,188	1	6	4,000
VH 2-8	10,200 - 13,600	8	1,584	2	8	4,600
VH 2-12	13,600 - 20,400	12	2,376	2	12	5,800
VH 2-16	20,400 - 27,200	16	3,168	2	16	7,700
VH 3-18	23,400 - 30,600	18	3,564	3	18	8,400
VH 2-20	26,000 - 34,000	20	3,960	2	20	N/A
VH 3-24	31,200 - 40,800	24	4,752	3	24	11,400
VH 3-30	39,000 - 51,000	30	5,940	3	30	N/A

* Based on clean filters.

** Shipping weight is for units with 60° single hopper and high body inlet (approximate).

Operating Conditions for VH Collectors

Seismic Spectral Acceleration	$S_s = 1.5 g$ $S_1 = 0.6 g$
Basic Wind Speed and Exposure (mph)	90 mph, Exposure C
Housing Rating ("wg)	± 20
Compressed Air Required (psig)	90-100
Operating Temperature	150°F
Housing Construction	3/16" - 10-gauge steel compliant with IBC 2006
Control Voltage	120 VAC -or- 24 VDC

VH Series Applications



VH 2-8 on Blasting



VH 1-6 on Grinding



VH 2-12 on Blasting

Standard Features & Available Options

Collector Design	Std	Opt
Robust, Welded Mild Steel Construction	X	
Clean-Side, Tool-Free Filter Pack Removal	X	
Quick Release Filter Tray Levers	X	
High Body Inlet	X	
Inlet Transitions		X
ZERO-Turn Pulse Cleaning System	X	
Diaphragm/Solenoid Valve and Manifold Combination	X	
Cleaning System Weather Cover		X
Mountable Fan Package		X
Filter Access Platform		X
Filter Packs		
PowerCore with Ultra-Web (MERV* 13)	X	
PowerCore FR (Flame Retardant) with Ultra-Web (MERV* 13)		X
Paint System		
Textured Multi-Coat Paint Finish with 2,000 Salt Spray Performance	X	
Custom Colors, Materials and Finishes		X ☆
Hopper Design		
Multiple Pyramid Hopper	X	
Single Pyramid Hopper		X
Single Pyramid Hopper (45 Degree) for 55-Gallon Drum		X
45° Short Hopper		X
60° Hopper		X
Hopper Access Panel	X	
Hopper Access Panel with Overflow Valve		X
Hopper Inlet		X

Hopper Discharge	Std	Opt
Slide Gate Packs		X
55-Gallon Drum Covers		X
Rotary Valves and Transitions		X
Dumpster Discharge		X
Support Structure		
48" Clearance Beneath Hopper for 55-Gallon Drum	X	
72" Clearance Beneath Hopper for Rotary Valves		X
62" Clearance Beneath Hopper for Dumpster Discharge		X
Leg Extensions		X
Electrical Controls, Gauges and Enclosures		
Control Box NEMA Type 4 with Timer	X	
Delta P Control NEMA Type 4 with Timer		X
Delta P Plus Control NEMA Type 4 with Timer		X
Prewired Junction Box to Solenoid Valves		X
Magnehelic [®] *** Gauge	X	
Photohelic [®] *** Gauge		X
110 VAC Control Voltage	X	
24 VDC Control Voltage		X
Heavy Duty Cold Climate Kit		X
Custom Control Panels		X
Safety Features		
Sprinkler Couplings	X	
Explosion Vents		X
Warranty		
10-Year Warranty	X	

* The Minimum Efficiency Reporting Value (MERV) of this filter cartridge has been determined through independent laboratory testing using ASHRAE 52.2 (2007) test standards. The MERV rating was determined at a face velocity of 118 feet per minute and loading up to four inches water gauge. Actual efficiency of any filter cartridge will vary according to the specific application parameters. Dust concentration, airflow, particle characteristics, and pulse cleaning methods all affect filtration efficiency.

** Magnehelic and Photohelic are registered trademarks of Dwyer Instruments, Inc.

Leading Technology

- Over 1,000 engineers and scientists worldwide
- Broad range of innovative collectors and filters
- 100s of filter media formulations

Experience and Service

- Technical expertise and support
- Ready-to-ship filters and parts within 24 hours
- 1,000,000+ dust, fume and mist collectors installed

Global Support

- Facilities in 37 countries
- 40 manufacturing plants and 14 distribution centers

Call Donaldson® Torit® to get cleaner air today:

800 365-1331

Donaldson.com/ToritPowerCore



Donaldson Company, Inc.
Torit
P.O. Box 1299
Minneapolis, MN
55440-1299 U.S.A.

Tel 800-365-1331 (USA)
Tel 800-343-3639 (within Mexico)

donaldsontorit@donaldson.com
donaldson.com

Torit PowerCore VH Series (06/11)
© 2011 Printed in the U.S.A. All Rights Reserved. Information in this document is subject to change without notice.